

# 《15日(土) タイムテーブル》 【 T:男子団体 S:女子個人 】

コート 試合順	1 10:00 ~	2 10:50 ~	3 11:40 ~	4 12:30 ~	5 13:20 ~	6 14:10 ~	7 15:00 ~	1 12:15 ~	2 12:40 ~	3 13:05 ~	4 13:30 ~	5 13:55 ~	6 14:20 ~	7 14:45 ~	8 15:10 ~	コート 試合順
1	T	T	T	T	T	T	T									1
2	1-1	2-1	2-2	3-1	3-2	4-1	5-1									2
3																3
4	T	T	T	T	T	T	代表 決定戦									4
5	1-2	1-9	2-3	2-6	3-3	4-2										5
6																6
7	T	T	T	T	T							S3-1				7
8	1-3	1-10	2-4	2-7	3-4							S3-2	S4-1	S5-1	S6-1	8
9												S3-3	S4-2			9
10	T	T	T	T								S3-4	S4-3	S5-2		10
11	1-4	1-11	2-5	2-8								S3-5	S4-4			11
12												S3-6				12
13	T	T	女子個人 参加選手 練習 11:40 ~ 12:10						S1-1	S1-13	S1-25	S2-5	S3-7			13
14	1-5	1-12							S1-2	S1-14	S1-26	S2-6	S3-8			14
15									S1-3	S1-15	S1-27	S2-7				15
16	T	T							S1-4	S1-16	S1-28	S2-8				16
17	1-6	1-13							S1-5	S1-17	S1-29	S2-9				17
18									S1-6	S1-18	S1-30	S2-10				18
19	T	T							S1-7	S1-19	S1-31	S2-11				19
20	1-7	1-14							S1-8	S1-20	S1-32	S2-12				20
21									S1-9	S1-21	S2-1	S2-13				21
22	T	T							S1-10	S1-22	S2-2	S2-14				22
23	1-8	1-15							S1-11	S1-23	S2-3	S2-15				23
24									S1-12	S1-24	S2-4	S2-16				24

※記載の時間を待たず、進行を早めたり、コートを変更したりする場合があります。

# 《16日(日) タイムテーブル》 【 T:女子団体 S:男子個人 】

コート 順	1 10:00 ~	2 10:50 ~	3 11:40 ~	4 12:30 ~	5 13:20 ~	6 14:10 ~	1 12:15 ~	2 12:40 ~	3 13:05 ~	4 13:30 ~	5 13:55 ~	6 14:20 ~	7 14:45 ~	8 15:10 ~	コート 順 No.
1	T	T	T	T	T	T									1
2	1-1	2-1	3-1	3-3	4-1	5-1									2
3															3
4	T	T	T	T	T	代表 決定戦									4
5	1-2	1-9	2-7	3-4	4-2										5
6															6
7											S4-1				7
8	T	T	T								S4-2	S5-1	S6-1	S7-1	8
9	1-3	2-2	3-2							S3-1	S4-3	S5-2			9
10										S3-2	S4-4	S5-3	S6-2		10
11	T	T	T												11
12	1-8	1-10	2-8							S2-25	S3-3	S4-5	S5-4		12
13															13
14	T	T					S1-1	S2-1	S2-27	S3-5	S4-7				14
15	1-5	2-4					S1-2	S2-9	S2-28	S3-6	S4-8				15
16							S1-3	S2-16	S2-29	S3-7					16
17	T	T					S1-4	S2-17	S2-30	S3-8					17
18	1-6	2-5					S1-5	S2-24	S2-18	S3-9					18
19							S1-6	S2-15	S2-19	S3-10					19
20	T	T					S2-2	S2-8	S2-20	S3-11					20
21	1-7	2-6					S2-3	S2-10	S2-21	S3-12					21
22							S2-4	S2-11	S2-22	S3-13					22
23	T	T					S2-5	S2-12	S2-23	S3-14					23
24	1-4	2-3					S2-6	S2-13	S2-31	S3-15					24
							S2-7	S2-14	S2-32	S3-16					24

※記載の時間を待たず、進行を早めたり、コートを変更したりする場合があります。

## 男子個人

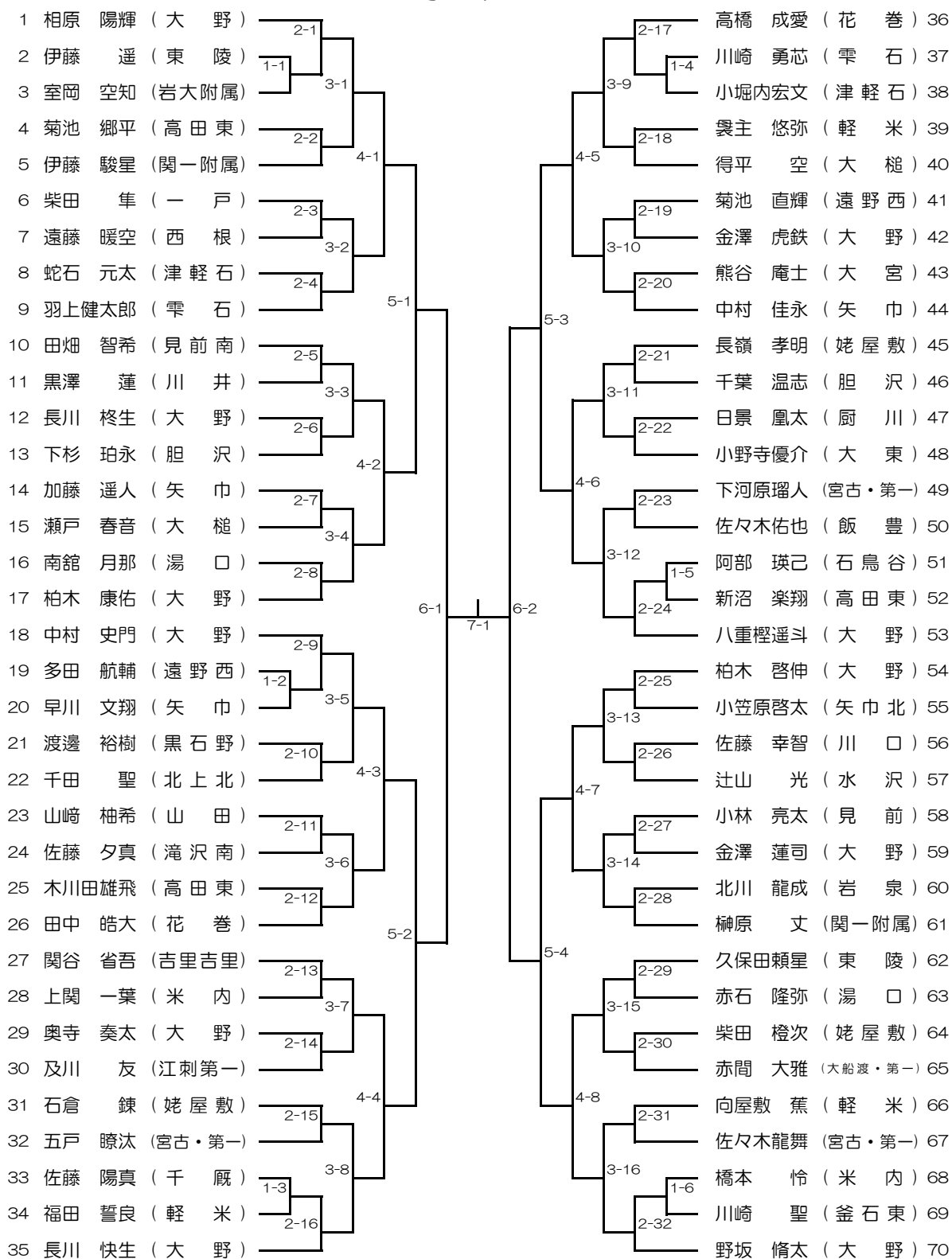

# 男子団体

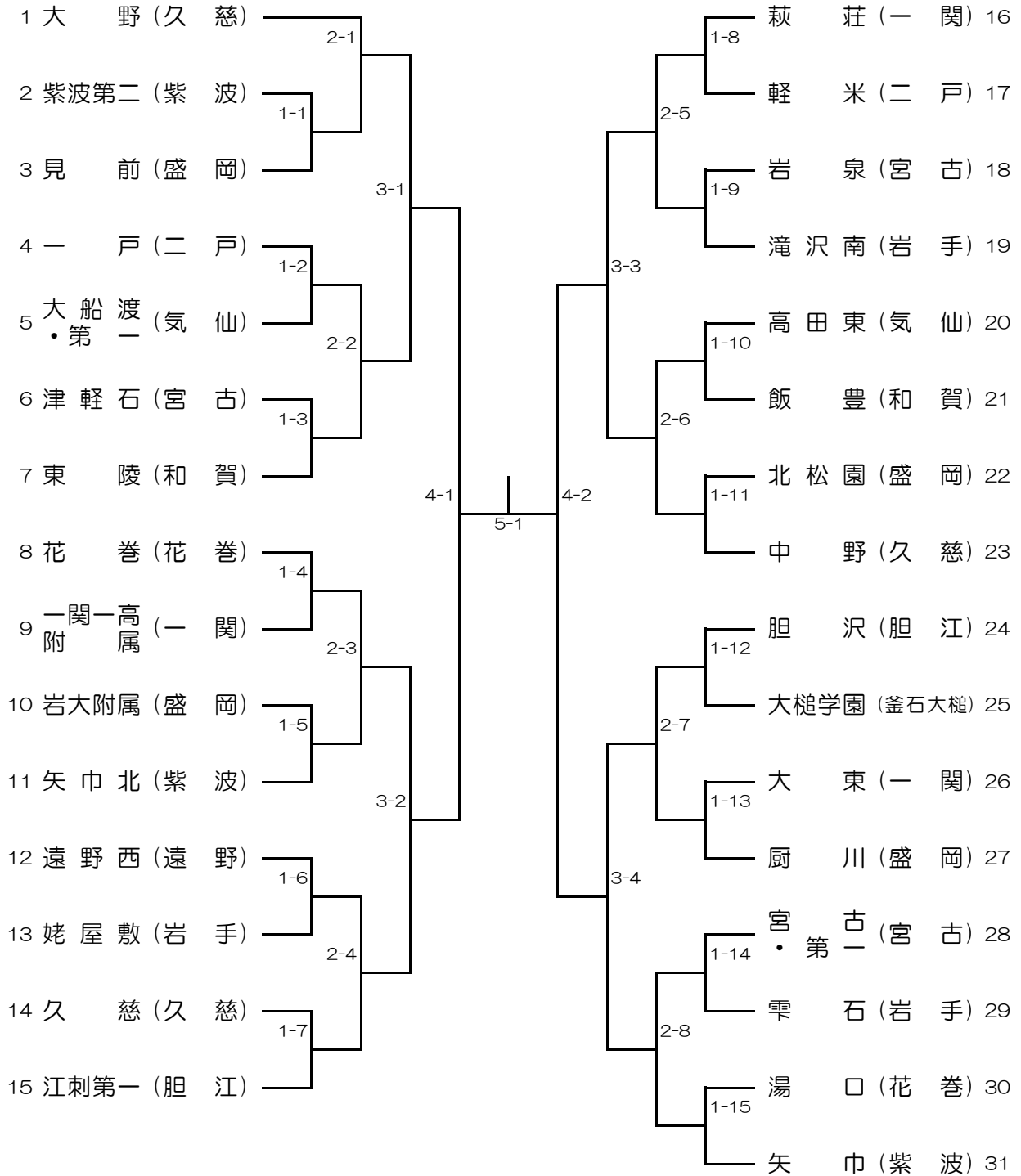

( )

東北大会代表決定戦

( )

# 女子個人

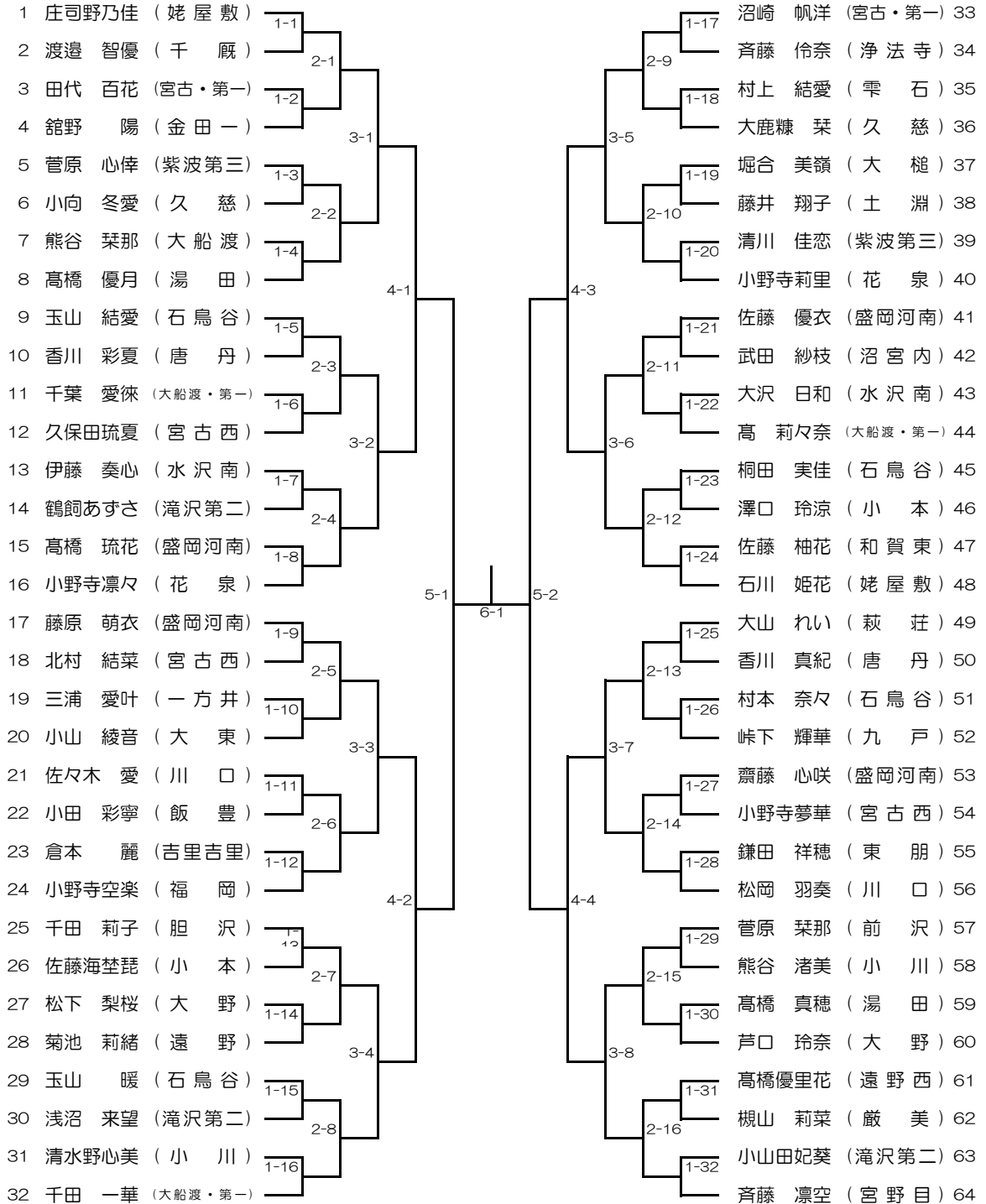

# 女子団体

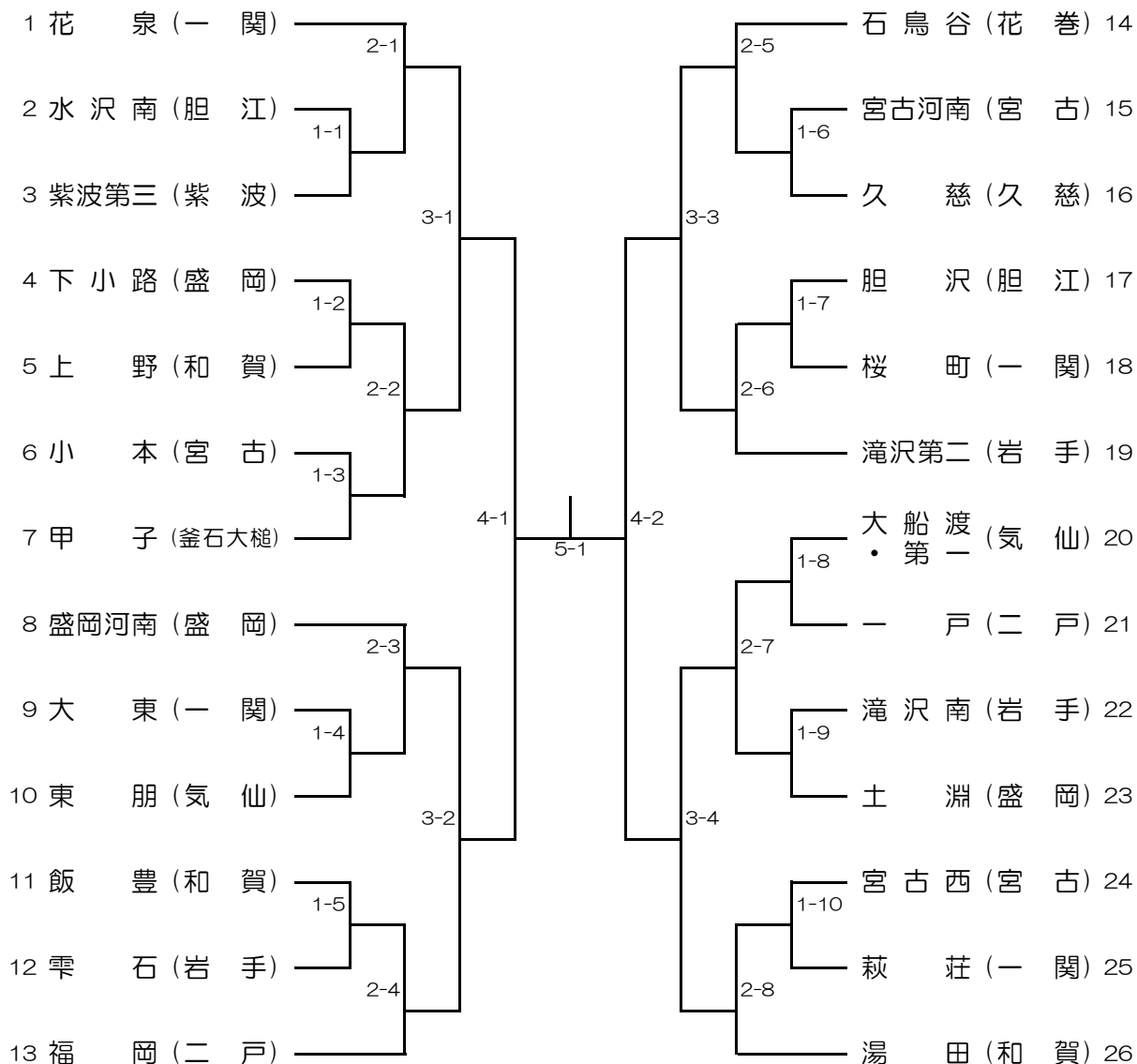

( )

東北大会代表決定戦

( )