

男子団体

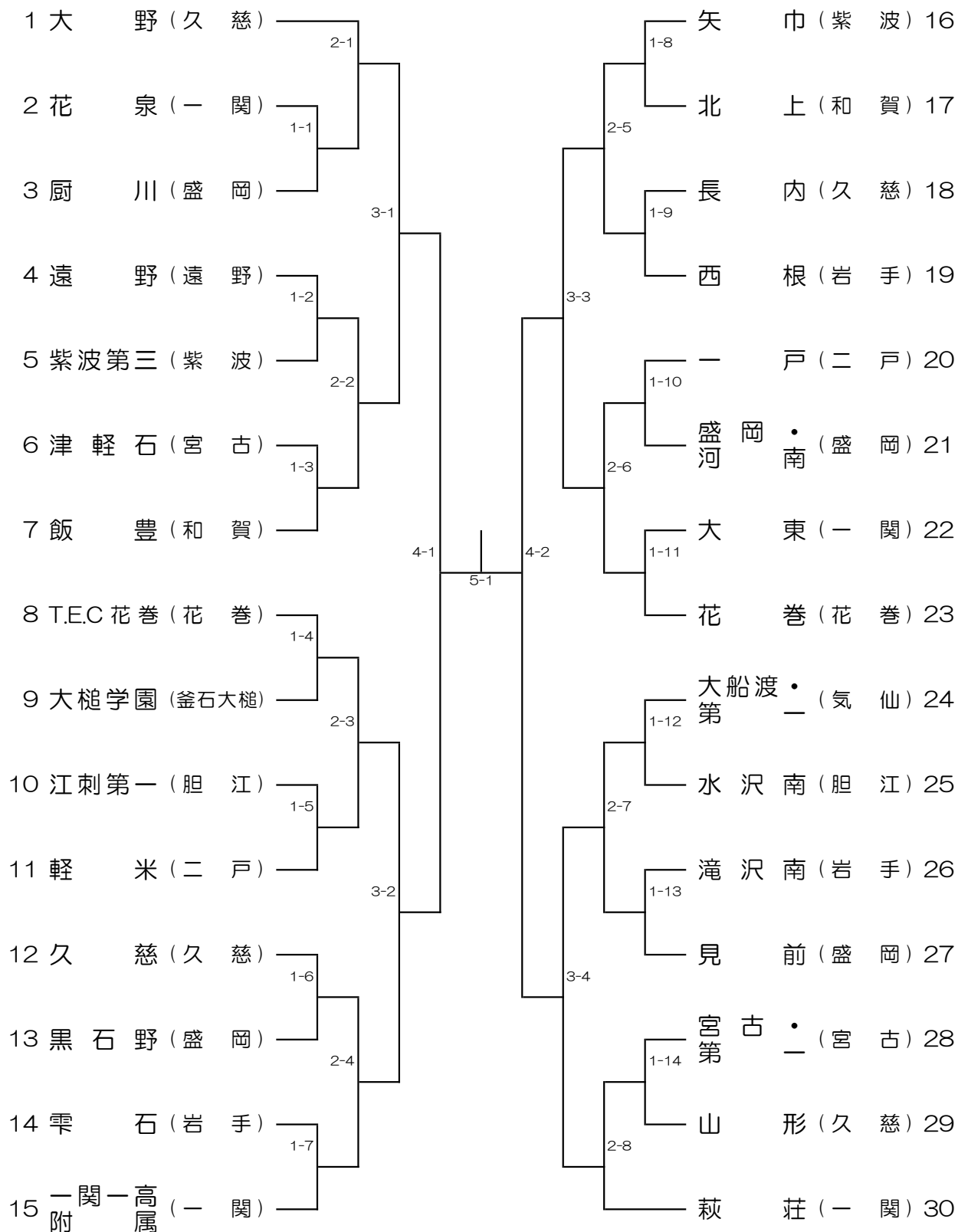

女子団体

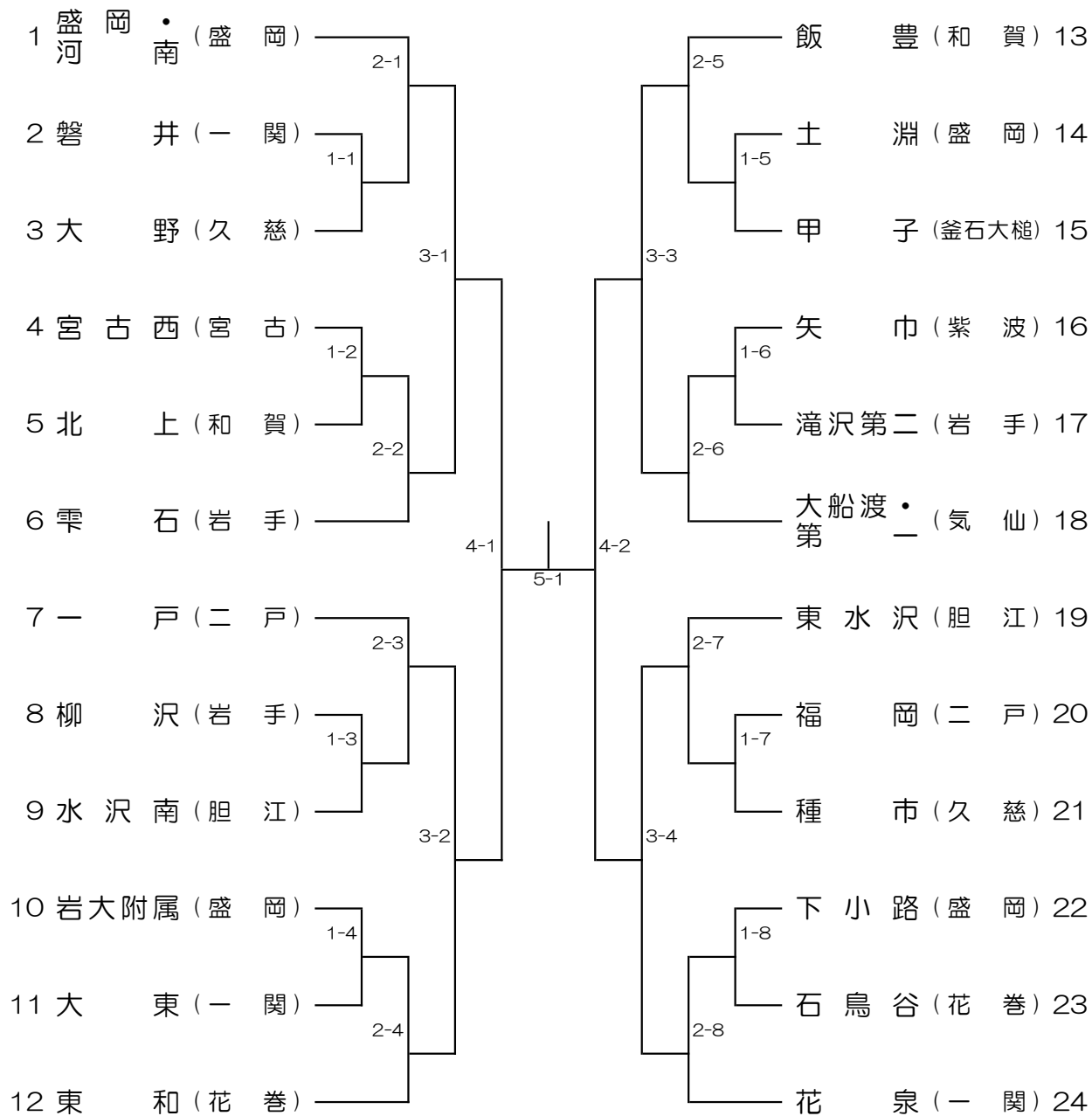

()

東北大会代表決定戦

()

男子個人

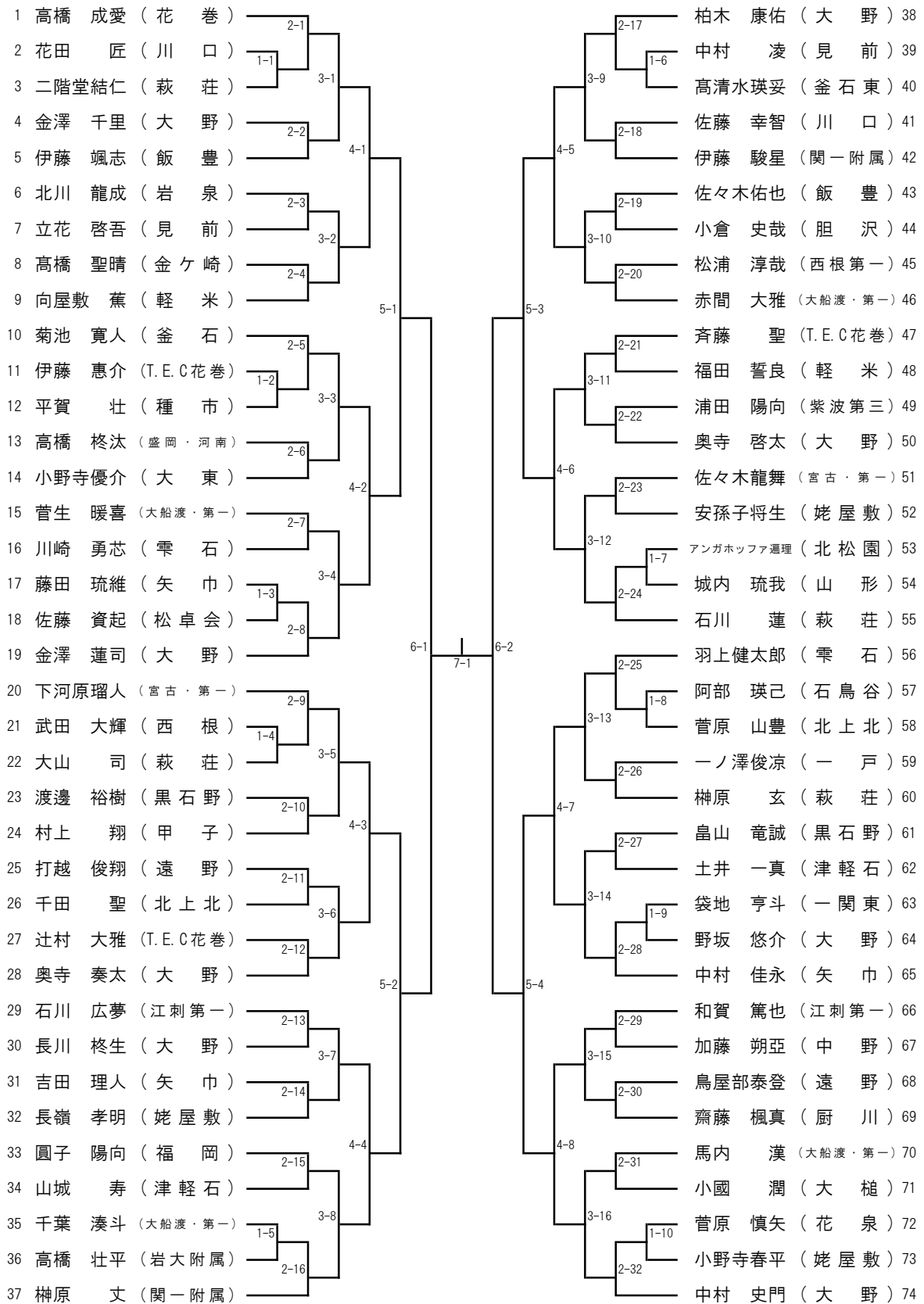

女子個人

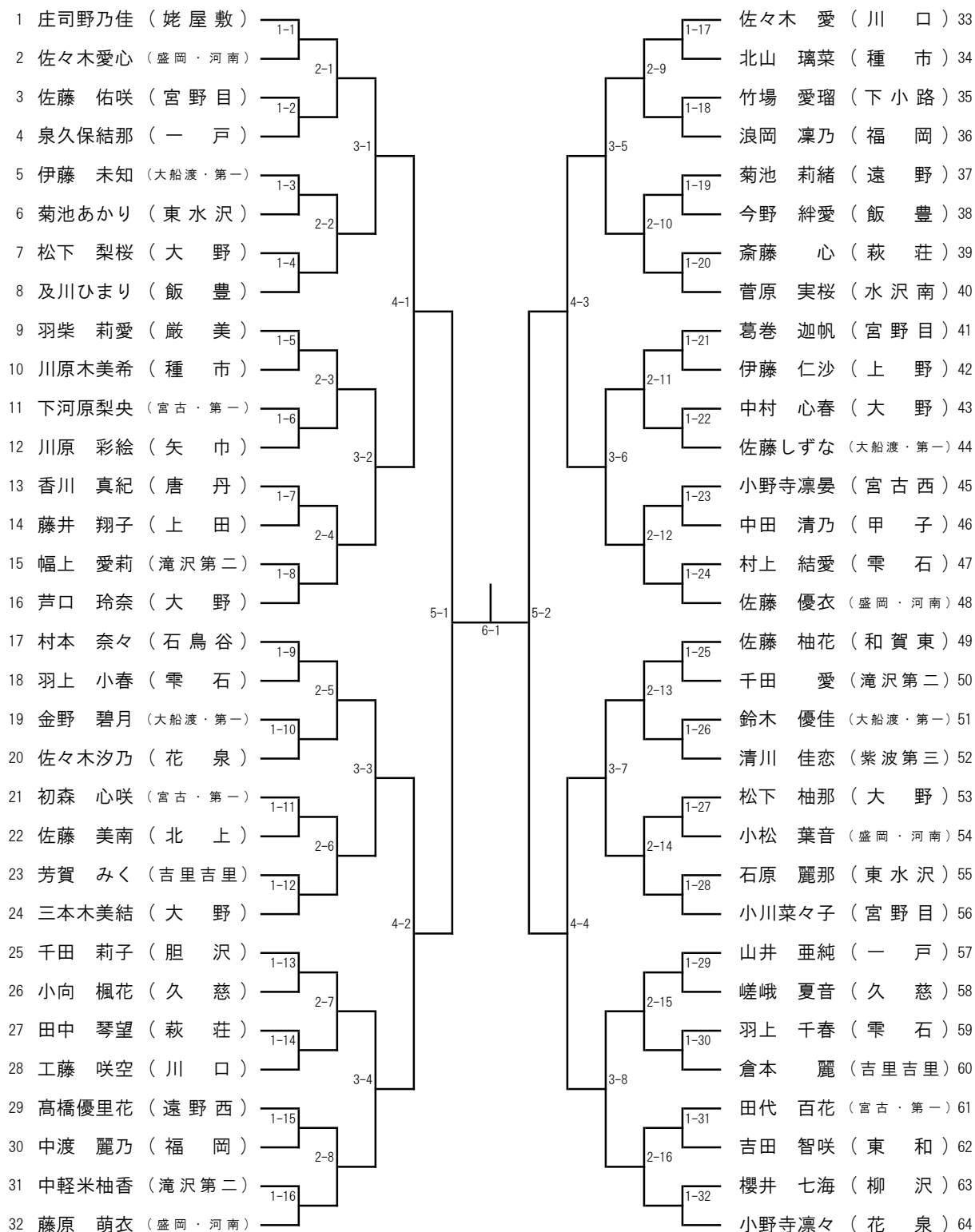

《13日(土) タイムテーブル》 【 T:男子団体 S:女子個人 】

コート 試合 No.	1 10:10 ~	2 11:00 ~	3 11:50 ~	4 12:40 ~	5 13:30 ~	6 14:20 ~	7 15:10 ~	1 12:25 ~	2 12:50 ~	3 13:15 ~	4 13:40 ~	5 14:05 ~	6 14:30 ~	7 14:55 ~	8 15:20 ~	コート 試合 No.
1	T	T	T	T	T	T	T									1
2	1-1	1-9	2-1	2-5	3-1	4-1	5-1									2
3																3
4	T	T	T	T	T											4
5	1-2	1-10	2-2	2-6	3-2											5
6						T	代表 決定戦									6
7	T	T	T	T	T	4-2										7
8	1-3	1-11	2-3	2-7	3-3											8
9																9
10	T	T	T	T	T								S4-1			10
11	1-4	1-12	2-4	2-8	3-4											11
12													S4-2	S5-1		12
13	T	T	女子個人 参加選手 練習 11:50 ~ 12:20					S1-1	S1-13	S1-25	S2-5	S3-1				13
14	1-5	1-13						S1-2	S1-14	S1-26	S2-6	S3-2	S4-3	S5-2	S6-1	14
15								S1-3	S1-15	S1-27	S2-7	S3-3				15
16	T	T						S1-4	S1-16	S1-28	S2-8	S3-4	S4-4			16
17	1-6	1-14						S1-5	S1-17	S1-29	S2-9	S3-5				17
18								S1-6	S1-18	S1-30	S2-10	S3-6				18
19	T							S1-7	S1-19	S1-31	S2-11	S3-7				19
20	1-7							S1-8	S1-20	S1-32	S2-12	S3-8				20
21								S1-9	S1-21	S2-1	S2-13					21
22	T							S1-10	S1-22	S2-2	S2-14					22
23	1-8							S1-11	S1-23	S2-3	S2-15					23
24								S1-12	S1-24	S2-4	S2-16					24

※記載の時間を待たず、進行を早めたり、コートを変更したりする場合があります。

《14日(日) タイムテーブル》 【 T:女子団体 S:男子個人 】

試合順 コートNo.	1 10:00 ~	2 10:50 ~	3 11:40 ~	4 12:30 ~	5 13:20 ~	1 12:15 ~	2 12:40 ~	3 13:05 ~	4 13:30 ~	5 13:55 ~	6 14:20 ~	7 14:45 ~	8 15:10 ~	試合順 コートNo.
1	T	T	T	T	T									1
2	1-1	2-1	3-1	4-1	5-1									2
3														3
4	T	T	T											4
5	1-2	2-2	3-2											5
6				T	代表 決定戦									6
7	T	T	T	4-2										7
8	1-3	2-3	3-3											8
9									S3-1					9
10	T	T	T				S2-4	S2-1	S3-2	S4-1	S5-1			10
11	1-4	2-4	3-4				S2-6	S2-5	S3-3	S4-2				11
12							S2-7	S2-8	S3-4	S4-3	S5-2	S6-1		12
13	T	T				S1-1	S2-10	S2-9	S3-5	S4-4				13
14	1-5	2-5				S1-2	S2-11	S2-16	S3-6	S4-5	S5-3	S6-2	S7-1	14
15						S1-3	S2-12	S2-17	S3-7	S4-6				15
16	T	T				S1-4	S2-13	S2-24	S3-8	S4-7	S5-4			16
17	1-6	2-6				S1-5	S2-14	S2-25	S3-9	S4-8				17
18						S1-6	S2-15	S2-26	S3-10					18
19	T	T				S1-7	S2-18	S2-27	S3-11					19
20	1-7	2-7				S1-8	S2-19	S2-28	S3-12					20
21						S1-9	S2-20	S2-29	S3-13					21
22	T	T				S1-10	S2-21	S2-30	S3-14					22
23	1-8	2-8				S2-2	S2-22	S2-31	S3-15					23
24						S2-3	S2-23	S2-32	S3-16					24

※記載の時間を待たず、進行を早めたり、コートを変更したりする場合があります。